



# Gastro-Haal

## USER MANUAL

for installation and maintenance

---

COMBINED RANGE

SPE-940 SC



7/2024

CE 1299

## Content

<b>1. General information</b>	<b>3</b>
<b>2. Use</b>	<b>3</b>
<b>3. Safety regulations</b>	<b>3</b>
<b>4. Legal Statement</b>	<b>3</b>
<b>5. Technical data</b>	<b>4</b>
<b>6. Description of the combined range</b>	<b>5</b>
6.1. Description of the cooking surface	5
6.2. Description of the electric oven	5
<b>7. Assembly</b>	<b>5</b>
<b>8. Changing the type of gas</b>	<b>6</b>
8.1. Setting the Eternal Flame	6
8.2. Adjusting the main burner	6
<b>9. Service</b>	<b>6</b>
<b>10. Operation</b>	<b>7</b>
10.1. Turning on the eternal flame	7
10.2. Adjusting the temperature in the oven	7
10.3. Turning off the device	7
<b>11. Maintenance and cleaning of the device</b>	<b>8</b>
<b>12. Attachments</b>	<b>10</b>
12.1. Burner holder	10
12.3. Electrical wiring diagram	11
12.4. Connection dimensions	12

The contact details of the supplier and service provider can be found on page 13.

## 1. General information

Dear user, thank you for choosing this product of ours. Please read these operating instructions carefully before using the appliance so that the appliance can serve you to your satisfaction.

## 2. Use

A combined range with a static oven is used for cooking and baking meals in school canteens, bistros, public catering establishments, etc.

## 3. Safety regulations

The manufacturer declares that the devices are in compliance with the regulations and applicable decrees of the European Union and the relevant government regulations.

**ATTENTION!** The manufacturer disclaims any liability in the event of direct and indirect damages related to improper installation, improper assembly or other causes.

The appliance must only be operated by qualified persons. Parts set by the manufacturer or a specialist service are strictly prohibited for the user to rebuild. It is forbidden to touch any parts of the appliance other than those specified by the control and manufacturer during operation. Furthermore, it is forbidden to clean and wash the appliance during operation. It is forbidden to use the appliance for any purpose other than that specified in the manual. Maintenance and repair can only be carried out when the appliance is switched off from the mains.

**Inspection by service personnel designated by the manufacturer once a year is recommended. When replacing spare parts, original spare parts must be used.**

The manufacturer is not responsible for defects caused by improper installation and operation.

## 4. Legal Statement

**A CUSTOMER WHO HAS BEEN ASSEMBLED, ADJUSTED AND REPAIRED BY AN ORGANISATION NOT AUTHORISED BY THE MANUFACTURING ORGANISATION CANNOT CLAIM THE COSTS ASSOCIATED WITH THE WARRANTY REPAIR WITH THE MANUFACTURER.**

**The operator of the combined range with a static oven must carefully study the instructions for use and operation. In the event of improper use and operation of the combined range with a static oven, the right to warranty repair !! is lost . The company will provide a warranty for the combined range with a static oven according to the enclosed "Warranty Card".**

**The oven door seals are not covered by the warranty!**

Defects that can be rectified by the user are not considered to be defects subject to warranty. Defects covered by the warranty will be repaired by the manufacturer's service organization or its representative.

**WARNING! THE MANUFACTURER IS NOT RESPONSIBLE FOR THE INCORRECT TECHNOLOGICAL PROCEDURE OF THE OPERATOR DURING COOKING AND BAKING!**

## 5. Technical data

<b>Line</b>	900
Type	<b>SPE-940 SC</b>
Description	combined range
External dimensions (mm)	900x900x900
Gas burners (pc)	4
Type of oven	static, hot air
<b>Heating</b>	
Gas connection (")	1/2"
Input of burners (kW)	1x3,7/2x4,8/1x7
Input of oven (kW)	4,1 kW
Input in total (kW)	20,3
Nominal current (A)	10
Nominal voltage (V)	3 N - 400V, 50Hz
Nominal gas pressure <b>(G-20)</b> kPa	2
Nominal gas pressure <b>G31</b> - propan - I3P (kPa)	3,7
Gas consumption <b>G20 - I2H (m<sup>3</sup>/h)</b>	2,03
Gas consumption <b>G31 propane - I3P (m<sup>3</sup>/h)</b>	0,79
Gas consumption <b>G31 propane - I3P (kg/h)</b>	1,59
Thermostat range (°C)	50 - 300 °C
Possible cooking temperature (°C)	50 - 320 °C
<b>Protection</b>	
Index of protection	IP 41
<b>Construction, savings, safety</b>	
Inserts in oven (pc)	3
Sound signalling	yes
Rounded edges without danger corners and protrusions	yes
Adjustable feet	yes
Weight (kg)	130
<b>Options for extra fees according of valid Price list</b>	
Enameled trays	yes (extra fee)
Stainless steel rack	yes (extra fee)
Grid for small pots (reduction on burner)	free of charge

**Pull the protective film off the grille before using it for the first time!**

**Combined range accessories are not included in the price!**

## 6. Description of the combined range

The combined cooker with a static oven is made of food-safe stainless-steel material. The structure of the device is self-supporting (kit system) and is equipped with adjustable feet to compensate for floor unevenness. At the top of the device there are four powerful gas burners, which are controlled individually via gas valves. Massive cast iron grilles are placed above these burners. At the bottom of the device there is an all-stainless steel, thermostatically controlled electric oven for roasting pans in dimensions GN 1/1 and GN 2/1.

### 6.1. Description of the cooking surface

- Four powerful burners with adjustable flame.
- Gas valves with safety component and regulator min.- max.
- An eternal flame is used to light each burner.
- The control button is made of thermoset.
- The cooking burners are equipped with a thermocouple for the safe operation of the device.
- Grid for small mugs (1 pc). Pull the protective film off the grille before using it for the first time!
- Four solid cast iron burner grates
- Two stainless steel trays under the burners – easy to clean

### 6.2. Description of the electric oven

The inner space of the oven itself is stainless steel with dimensions of 600x360x740mm. The furnace door is full. The oven is separately equipped with a main switch, a working thermostat and indicator lights, with a fan and two heating elements. The outer shell of the assembly is made of food-grade stainless steel material. The rear cover of the oven is removable and allows better access and handling of the inlets to the heating elements. At the bottom right is the main connection terminal block. The electrical wiring is under the front panel on the right side of the oven.

## 7. Assembly

Wiring, assembly and repairs to the equipment may only be carried out by an organization or a person authorized by the manufacturer for the specified works!

The combined range is set to a horizontal position. The protective film is removed from the trays of the device so that it does not burn during operation. The gas and electricity connection is located at the bottom of the device, on the right side. (*subchapter 7.1. Connection dimensions*).

These connections can be accessed as follows:

- **by removing the front right control panel.** It is attached with a single screw located at the bottom of the panel. After dismantling the front panel and exposing it, we pull the supply cable through the insulation adapter, anchor it to the insulation bracket and connect it to the main terminal block marked U,V,W,N and the earthing protection terminal.

**CAUTION: before uncovering the protective covers to the terminals, the inlets must be disconnected!** The connection of the electrical and gas medium must be converted according to the applicable STN standards. The installer checks the gas distribution system for leaks and adjusts the burners. A gas shut-off valve must be installed in front of the device.

The device must be connected to the mains via a switch with a minimum contact distance of 3 mm, and the switch must be located near the combined range! The switch is not supplied by the manufacturer.

## 8. Changing the type of gas

If you want to change the type of gas, the nozzles of the cooking burners must be replaced (see technical table and Appendix 12.1.). After replacing the nozzles, the flame of the individual burners is set to minimal burning using the BY PASS screw. Changing the type of gas and setting the eternal flame can only be done by a service worker authorized by the production organization.

**Table 1 Description of natural gas burners G20 – I2H**

	<b>Burner power( ZP)</b>	<b>Inlet pressure</b>	<b>Nozzle diameter ZP</b>
<b>Large burner</b>	1 x 7 kW	2kPa	1.9 mm
<b>Middle burner</b>	2 x 4.8 kW	2kPa	1.6 mm
<b>Little Burner</b>	1 x 3.7 kW	2kPa	1.4 mm

**Table 2 Description of natural gas burners G31 - I3P**

	<b>Burner power( ZP)</b>	<b>Inlet pressure</b>	<b>Nozzle diameter ZP</b>
<b>Large burner</b>	1 x 7 kW	2kPa	1.9 mm
<b>Middle burner</b>	2 x 4.8 kW	2kPa	1.6 mm
<b>Little Burner</b>	1 x 3.7 kW	2kPa	1.4 mm

### 8.1. Setting the Eternal Flame

We get to the eternal burner as follows: we dismantle the cast iron grate, then the burner cover and the bowl under the burners. If we have reached the eternal flame, it is necessary to unscrew (key no. 11) the cover screw (Annex 12.2. /6). The perpetual flame can be set using the pressure regulating screw (Appendix 12.2./ 5). When loosening (towards the left) we increase, when screwing in (towards the right) we decrease the pressure. Next, it is necessary to adjust the air supply using a diffuser. It is located in the eternal flame holder. We turn it until the flame burns with a bluish flame without sparks.

### 8.2. Adjusting the main burner

The main burners are set by the manufacturer. However, if conversion to another type of gas is necessary, the nozzles must be replaced (Annex 12.1. /3). To adjust the individual burners, follow the instructions in point 8. Changing the type of gas.

## 9. Service

Improper handling is dangerous. The manufacturer is not liable for material damage if it occurred during improper handling (during commissioning of the device or during operation). The operator must be acquainted with the instructions for use and instructed.

Before first use, the cooker should be cleaned with a damp cloth (lukewarm water + neutral detergent) and wiped dry.

**Use of the device without supervision is prohibited! Used ointments and oils may catch fire during operation.** Faulty operation or malfunction of the equipment must be reported immediately to the service organization.

## 10. Operation

### 10.1. Turning on the eternal flame

Turn the control knob and at the same time push counterclockwise to position 2 on the gas valve. In this way, we activate the eternal burner with the thermocouple. At the first ignition, wait about 20 seconds for the gas to get into the gas distribution. We then light the eternal flame with direct fire. After lighting the eternal flame, the push button should be held for 10-15 seconds until the thermocouple heats up. When the eternal flame is extinguished, the action must be repeated. The burning of the eternal flame can be monitored through the inspection hole on the stainless steel hoop of the burner. The eternal flame automatically ignites the burner after turning the knob to the max. power or min. power position.

### 10.2. Adjusting the temperature in the oven

- Turn on the main switch, which is mounted in front of the device on the wall.
- We turn the main switch to the desired heating.
- When you turn the knob, the indicator light will light up, indicating a live device.
- We turn the knob of the working thermostat, which is located above the main switch. By setting the knob to the desired heat value, we put the heating into operation.
- The temperature inside the oven is sensed by a thermostat sensor.
- The mechanical timer knob can only be turned clockwise (otherwise it may be damaged).
- When the set temperature inside the furnace is reached, the thermostat automatically turns off and the indicator light goes out. In the event of a drop in temperature inside the oven during operation, the working thermostat switches on automatically and the indicator light comes on again.

### 10.3. Turning off the device

When cooking is finished, turn the knob of the main switch to the "0" position,, . After the end of daily operation, (if the device is out of operation for a long time), in the event of faulty operation or malfunctions, the device must be disconnected from the mains with the main switch.

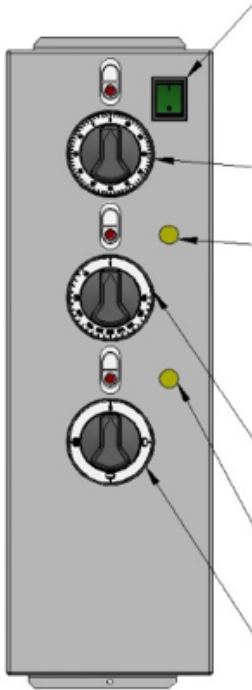

- Fan switch. Possibility to use independently from heating.
- Active only when the main switch is ON.
- Mechanical timer, numerical scale in minutes.
- Activated by switching of knob in clockwise. Switching in the opposite direction is forbidden, otherwise it may be damaged – is not subject of warranty!
- Does not affect the operation of the equipment, only the audio signal after the time limit has ended
- Control light to indicate heating function.
- Working thermostat, numerical scale in °C (degree of Celsius).
- Activating and temperature increase by switching of knob in clockwise. Switching of knob in the opposite direction means temperature reduction. Do not switch the knob by this way from the position 0.
- Starts the heating function.
- Active only when the main switch is ON.
- Yellow control light to indicate under voltage in the appliance.
- Appliance ready for heating.
- Main switch.
- Either direction of rotation

status OFF

active top and bottom heating

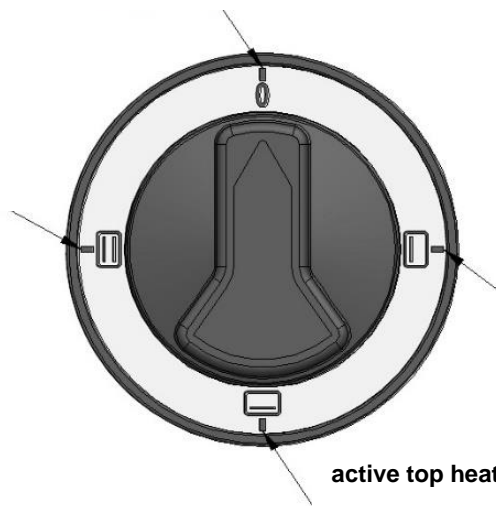

active bottom heating

active top heating



**WARNING!**

**The cooker must be switched off from the mains before cleaning and maintenance. The appliance must not be cleaned with splashing water!!**

**Any interference with the construction of the device IS PROHIBITED!!**

After the end of the day's operation, it is recommended to wash the combined range thoroughly by hand with lukewarm water with a neutral detergent and wipe it dry. Cleaning agents that could scratch these parts must not be used on stainless steel parts. Corrosion may occur. For this reason, contact between metal objects and stainless steel parts should be limited. For larger dirt, a synthetic sponge or brush should be used.

We recommend that the cast iron plates be cleaned while they are still warm with a scraper. To protect against corrosion, they need to be coated with oil.

Periodic inspection of the equipment by a service organization is recommended.

**For the treatment of GASTRO-HAAL equipment, the manufacturer recommends the use of TIEFFE cleaning products that are specially tested, tested and compliant by the manufacturer. It is possible to purchase TIEFFE cleaning products directly from the manufacturer of the GASTRO-HAAL equipment or from a retailer.**

## 12. Attachments

### 12.1. Burner holder

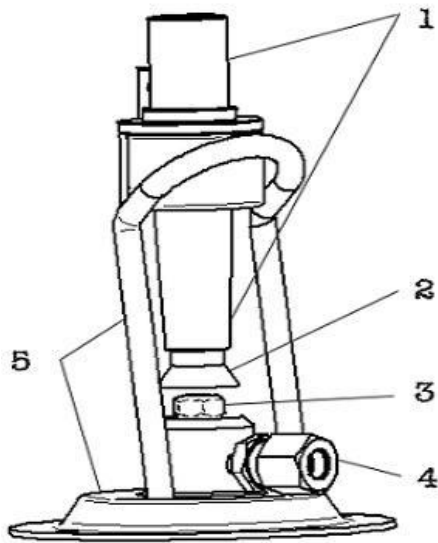

- 1 - Venturi tube
- 2 - Diffuser
- 3- Nozzle
- 4 - Gas supply reduction
- 5 - Burner stand

### 12.2. Eternal Burner Assembly

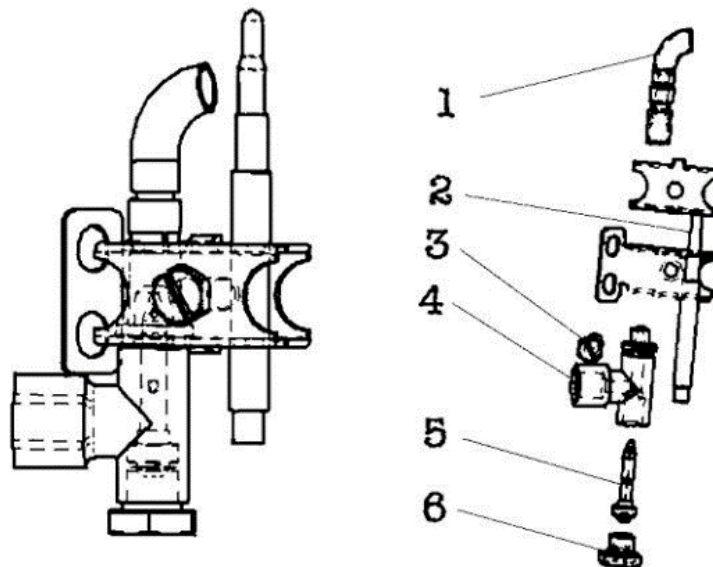

- 1. Eternal burner
- 2. thermocouple
- 3. Mounting screw
- 4. The body of the eternal burner
- 5. Pressure regulating screw
- 6. Spark mating

### 12.3. Electrical wiring diagram

SPE-940 SC

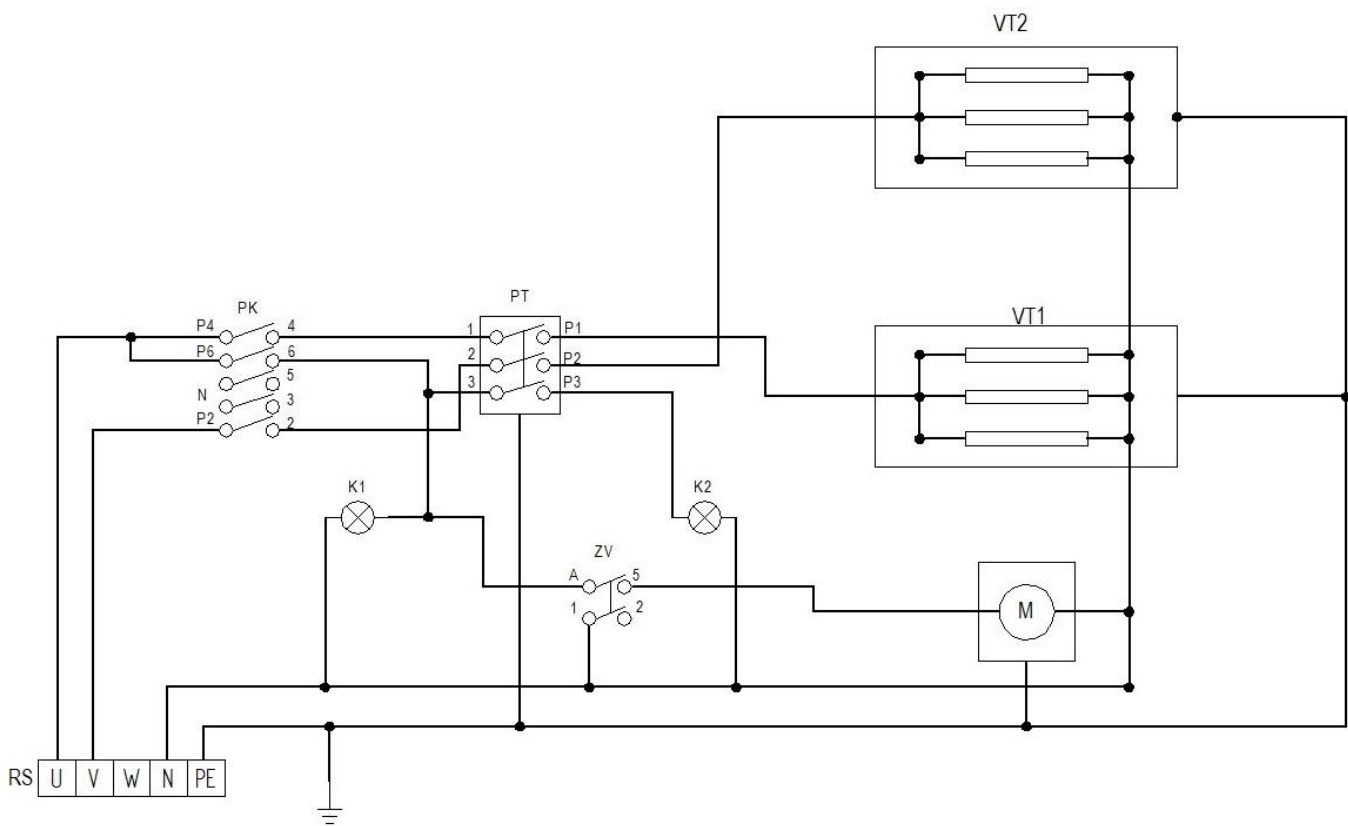

#### Legend:

- RS – In-line terminal block 400 V
- K1– Indicator light 230V (live oven)
- K2 – Indicator light 230V (oven heating)
- PK – Switch 42.04000.020 0-1-2-3 400V
- PT1 – Work thermostat 50-300°C 400V/16A
- M1 – Fan Motor 230V / 30W
- VT1 – Oven heating element lower 3x670W / 230V
- VT2 – Oven heating element upper 3x670W / 230V
- ZV1 – Green switch 230V / 16A

## 12.4. Connection dimensions

### SPE-940 SC

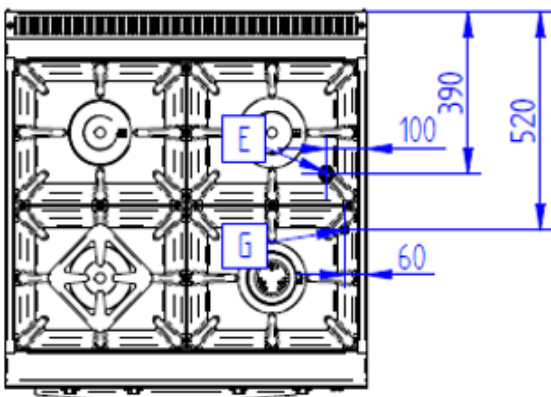
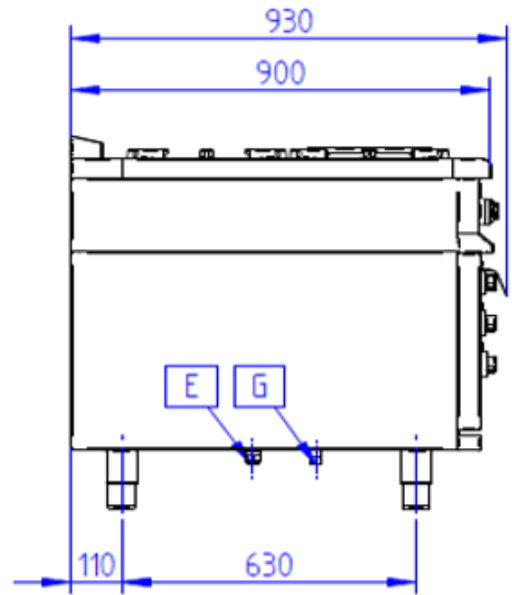
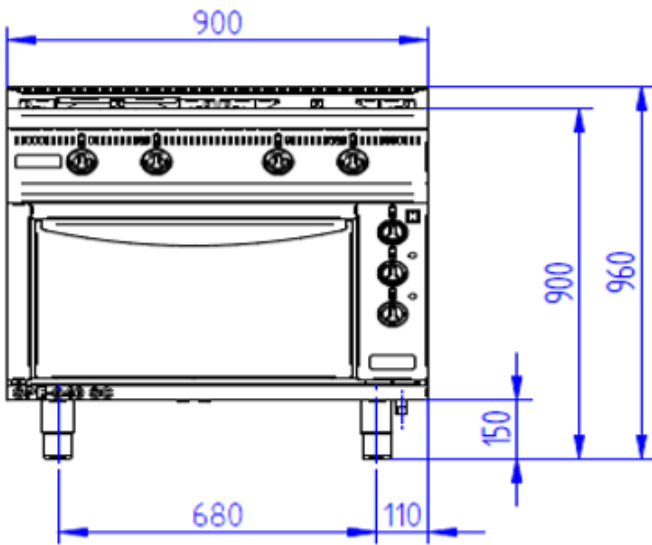

SPE-940 SC	
E	Electric connection
G	Gas connection G3/4

## **SUPPLIER:**

(add supplier contact here)

## **SERVICE PROVIDER:**

(add service contact here)

## **MANUFACTURER**

---

**GASTRO – HAAL, s.r.o.** Považská 16, 940 67 Nové Zámky, SR +421 35 6 430 115  
Company ID: 31435076 VAT ID: 2020413659 VAT ID: SK2020413659

[gastro@gastrohaal.sk](mailto:gastro@gastrohaal.sk)  
[www.gastrohaal.sk](http://www.gastrohaal.sk)