

Product: **Boiling pan - gas**
Producer: **Gastro-Haal, s.r.o.**

Type: **KG-85-O**
Country of origin: **SK**

Purpose

Gas boiling pans is a basic unit in large-scale kitchens as a school dining hall, restaurants, hospitals, all types of canteens, including of military, etc. Boiling pans is designed for cooking of soups, sauces, meat, pasta, dairy meals without any danger of burning, for stewing of fish, vegetable, mushrooms, etc. and for heating of frozen meals and semi-finished food.

The food is cooked by steam which is generated in double shell (duplicator).

Features of KG-85-O:

- **analogy control panel**
- **volume of cooking tank 85 litres**
- manual opening lid to an angle approx.80°
- **round cooking tank (indirect heating)**
- thermal and protective insulation of duplicator
- probes for measuring the water level in the duplicator
- automatic water filling
- tap for cold water
- safety fitting/valve with manometer
- outlet valve 2"
- outlet tube to valve 2" for bigger pieces of food
- **power supply: gas**
- fast heating of cooking tank, low consumption of energy and low operating costs
- quiet, safe, and noiseless operation
- controlled turning On and Off of burners
- 2 tubes chrome-plated burner made of high-quality material
- double insulation on cables and wires (silicone protection)
- **self-supporting massive and solid construction**
- top plate, inner and outer shell of tank, and lid made of AISI 304
- inner bottom of cooking tank made of high-quality stainless steel AISI 316L
- rounded edges without danger corners and protrusions
- bottom cover of boiling pan
- adjustable feet
- **simple operation**



Standard accessories of boiling pan:

- sieve in front of outlet valve for catching food

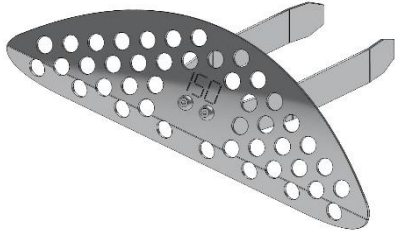
Available accessories for sales

- round steamer for dumplings
- food Vaseline for daily maintenance of outlet valve

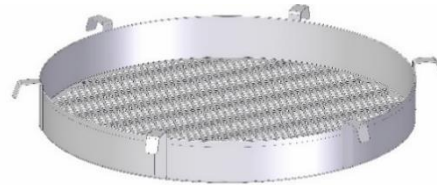
Front panel

- classic analogy
- 2 levels of heating (SAVING mode, FULL mode)

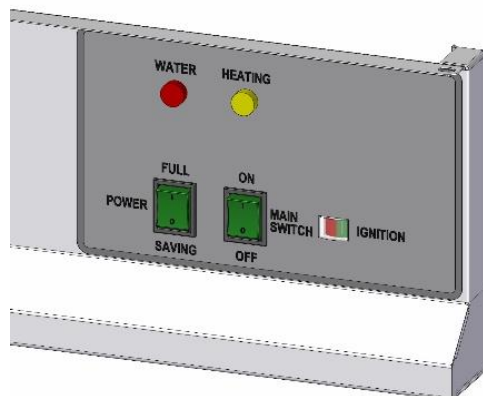
What is the duplicator?

Duplicator is closed steam tank designed for indirect heating of boiling pan cooking tank. The warm is therefore supplied from the burners through steam, which is developed between the duplicator and supplies the boilers - a double layer.

Duplicator is equipped with a safety fitting that protects the equipment from excessive overpressure, ensures that is vented before cooking and the re-aerated at the end of cooking. The safety fitting includes the manometer which controls the pressure in duplicator. The boiling pan includes the pressure switch.

Duplicator therefore ensures the smooth heating, and the food does not burn.



Technical descriptions

Line	900
Type	KG-85-O
Description	gas boiling pan
Front panel	classic analogy
External dimensions (mm)	700x900x900 mm
Volume of cooking tank (l)	85 l
Duplicator	round
Duplicator volume (in intermediate jacket) (l)	31 l
Water volume in duplicator (after level sensor)	12 l
Water capacity in duplicator (l)	10 l
Automatic filling of water in to duplicator	yes
Nominal pressure of duplicator (bar)	0,4 bar
Heating	
Gas connection (")	3/4"
Nominal gas pressure G20 - I2H (kPa)	2 kPa
Nominal gas pressure G31 propane - I3P (kPa)	3,7 kPa
Gas tube burners	2 tubes burner
Electrical input (W)	25 W
Nominal burner input (kW)	11,2
Gas consumption G20 - I2H (m ³ /h)	1,2
Gas consumption G31 propane - I3P (m ³ /h)	0,43
Gas consumption G31 propane - I3P (kg/hod)	0,88
Nominal voltage	230 V + PEN 50 Hz TN-S
Setting excess max. pressure on the nozzle in Mbar (G20)	14,5 Mbar
Setting excess max. pressure on the nozzle in Mbar (G31)	22 Mbar
Saving pressure on the nozzle in Mbar (G20)	8,5 Mbar
Saving pressure on the nozzle in Mbar (G31)	16 Mbar
Nozzle diameter (G-20) (mm)	2
Nozzle diameter (G31) (mm)	1,4
Nozzles (pc)	2 pc
Water heating time in a brewing pot 20-90°C (min.)	50 min
Water, valve, protection	
Cold water connection (")	3/4 "
Max. water pressure (bar)	6 bar
Outlet valve (")	2"
Outlet tube to valve (")	2"
Index of protection	IP 41
Construction, savings, safety	
Pressed top plate for water outfall	no
Double insulation on cables and wires (silicone protection)	yes
Sloping chimney on top plate	yes
Rounded edges without danger corners and protrusions	yes
Thermal and protective insulation of duplicator	yes
Weight (kg)	100 kg
Covering of bottom	yes

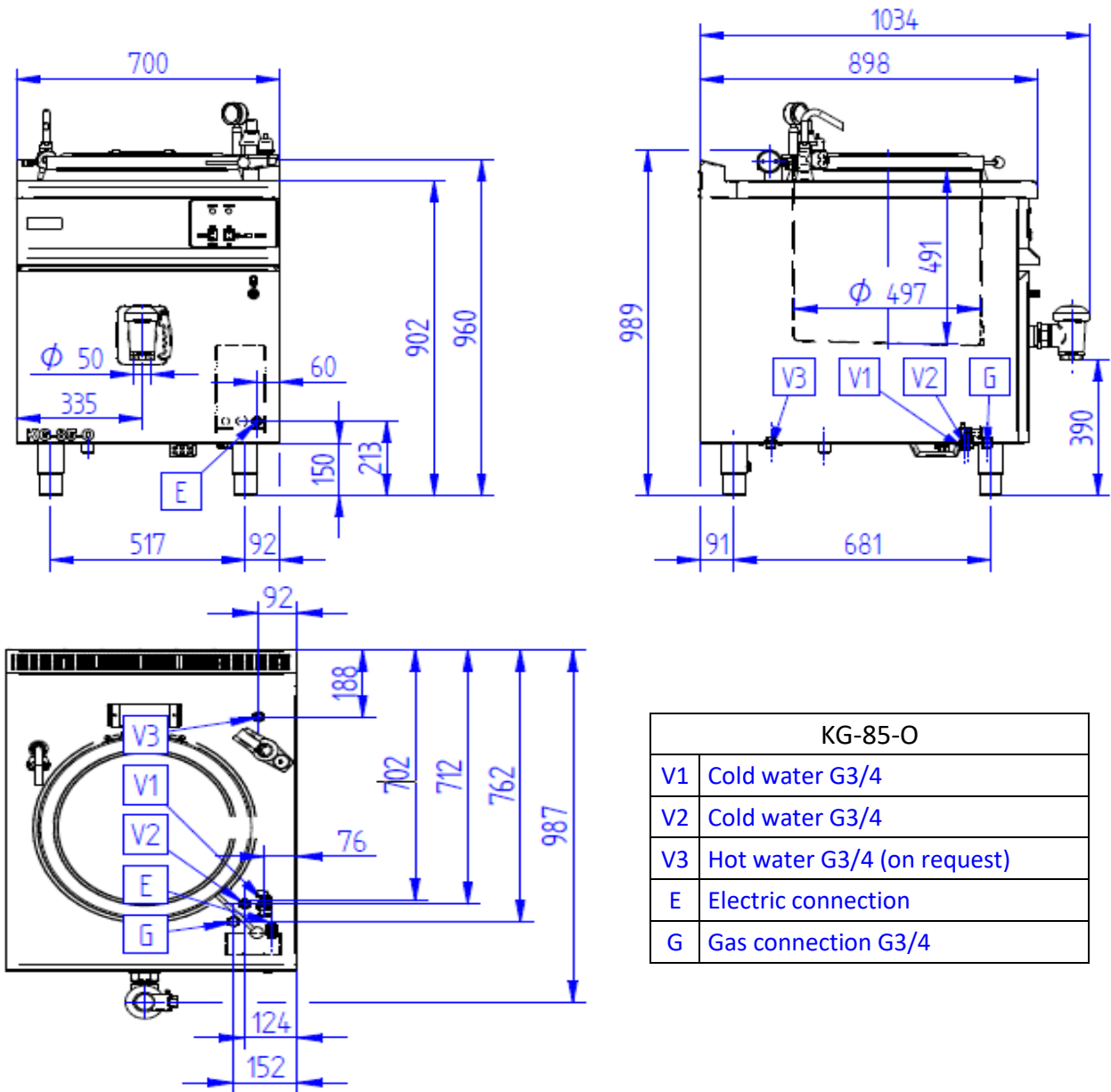

Options for extra fees according of valid Price list	
Cooking temperature setting (thermostatic control) "T" from 30 to 100 °C	yes (extra fee)
Cooking tank material AISI	AISI 316 (tank bottom) standard
Chimney	yes (extra fee)
2x water supply with tap hot and cold water 3/4"	yes (extra fee)
Vaseline for outlet valve	yes (extra fee)
Cooking baskets	yes (extra fee)
Steamers	yes (extra fee)
Dumplings maker	yes (extra fee)
Hard water softener	yes (extra fee)
Sieve in front of outlet valve	free of charge
Adjustable feet	yes
Info	
G20 - I2H = natural gas	
G31 propane - I3P = propane	

Technical dimensions

KG-85-O	
V1	Cold water G3/4
V2	Cold water G3/4
V3	Hot water G3/4 (on request)
E	Electric connection
G	Gas connection G3/4