

Product: **Tilting bratt pan - electric**
Producer: **Gastro-Haal, s.r.o.**

Type: **PE-980**
Country of origin: **SK**

Purpose

Electric tilting bratt pan is used for heat treatment of food by frying in oil or stewing in water (in juice). It is intended for large-scale kitchens as a school canteen, restaurants, hospitals, all types of canteens, including of military, etc. The most frequently prepared dishes in frying pan are rice, pancakes, ragout, sauté, schnitzels, etc.

Stainless steel bottom of cooking tank is more suitable for dishes with a juicier base. The dishes are heated by burners located under the tank. They can be simply covered with lid and tipped out using a rotating wheel.



Features of PE-980:

- **stainless steel tank**
- rotating wheel for tilting
- square tank
- **volume 80 litres**
- button for filling of water, tap for cold water
- control panel, thermostat range 50°C - 250°C
- **power supply: electricity**
- fast heating of cooking tank
- 9 tubes chrome-plated burner for even heat distribution and energy saving
- quiet, safe, and noiseless operation
- low operating costs
- **self-supporting massive and solid construction**
- tank placed in the shaped top plate „U“ gutter for waste collection
- rounded edges without danger corners and protrusions
- double insulation on cables and wires (silicone protection)
- manual opening lid
- adjustable feet
- **simple operation**

Standard accessories included in the price:

- hatch
- cold water battery for steaming
- turning wheel
- adjustable feet

Available accessories for sales price:

- square steamer for dumplings

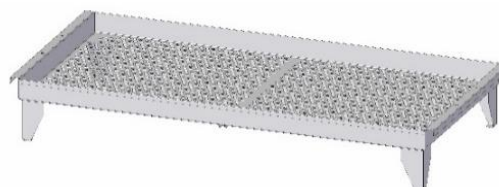

Front panel

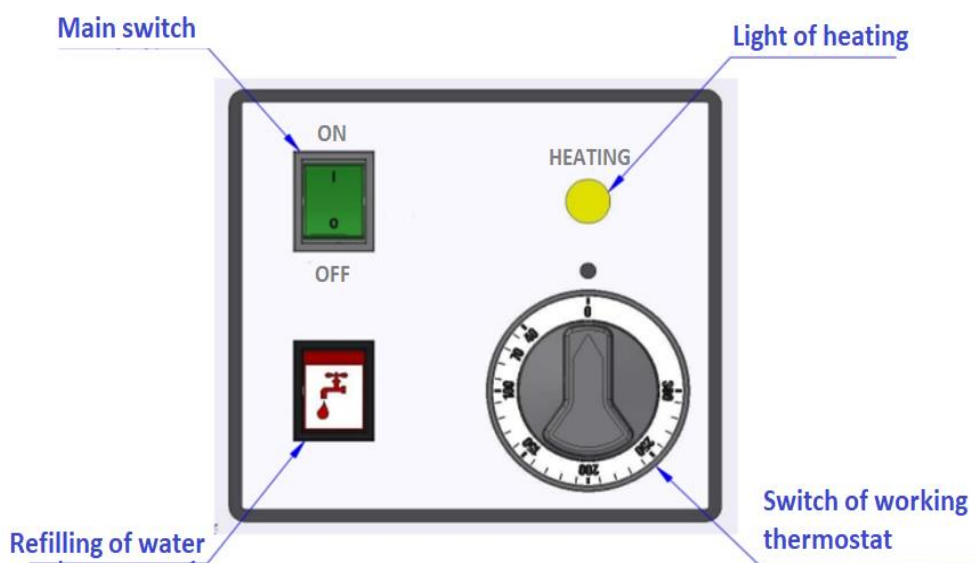

Stainless steel tank

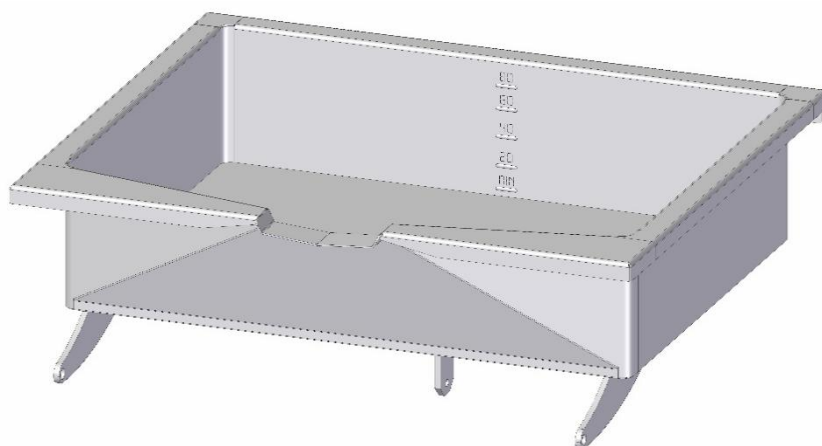

**Technical descriptions**

Line	900
Type	PE-980
Description	electric tilting bratt pan
Front panel	classic analogy
Bottom of cooking tank	stainless steel
External dimensions (mm)	900x900x900
Dimensions of cooking tank (mm)	800x600x192
Total volume of cooking tank (l)	94,6 l
Usable volume up to the height drain of the cooking tank (l)	82,3 l
Usable volume of the cooking tank (max. line) (l)	75,2 l
Heating	
Heating elements (pc)	9 pc
Nominal el. input (kW)	13,5 kW
Nominal voltage	3 N - 50 Hz / 400V
Nominal current	21 A
Thermostat range (°C)	50 - 250 °C
Possible cooking temperature (°C)	50 - 250 °C
Maximum highest cooking temperature by setting up to 250 °C	280 - 300 °C
Water, valve, protection	
Cold water connection (")	3/4
Index of protection	IP 41
Filling the tap water with the button	yes
Construction, savings, safety	
Tap for cold water	yes
Double insulation on cables and wires (silicone protection)	yes
Rounded edges without danger corners and protrusions	yes
Adjustable feet	yes
Weight (kg)	160 kg
Options for extra fees according of valid Price list	
Square steamer	yes (extra fee)

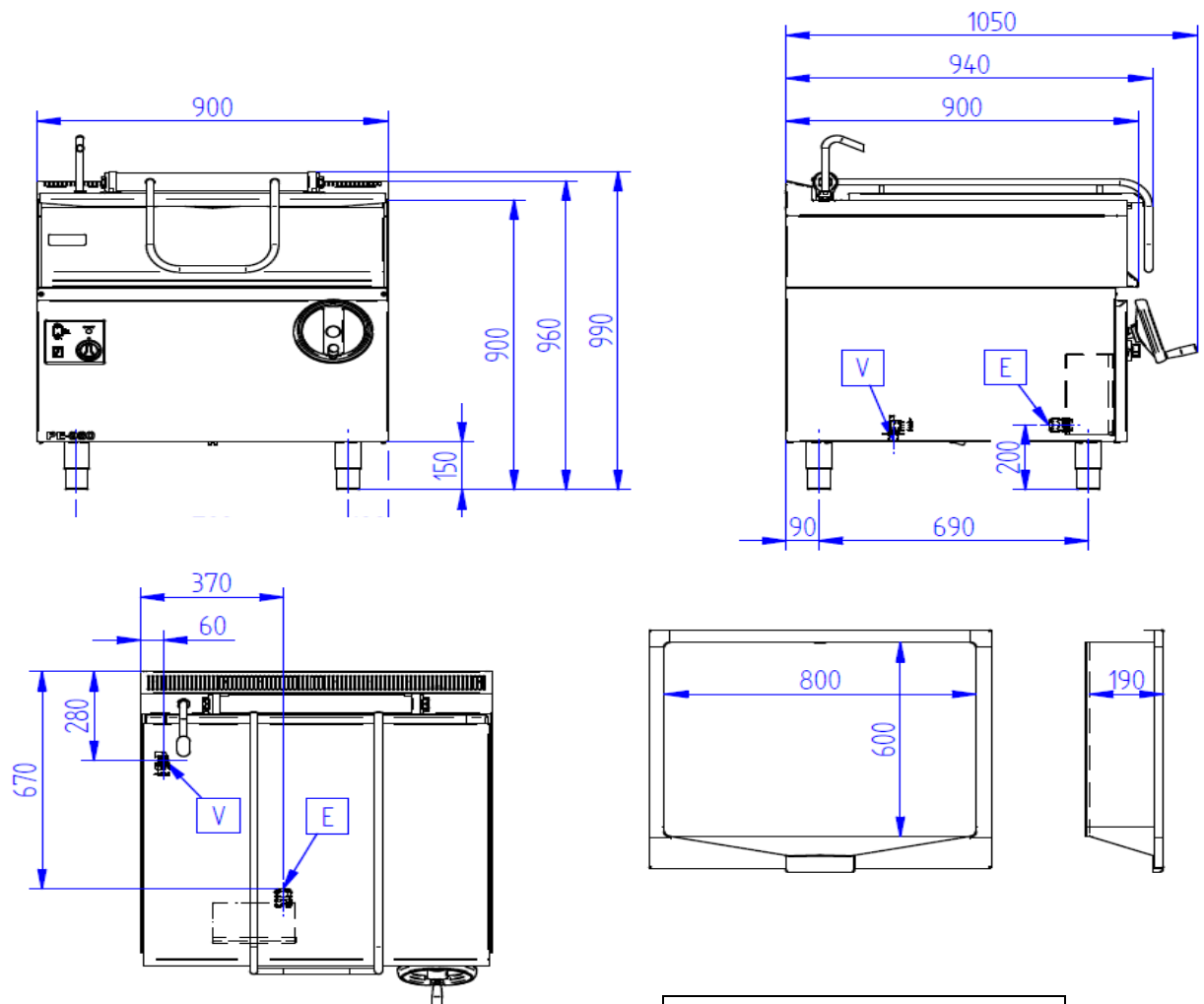
Technical dimensions

PE-980	
V	Cold water G3/4
E	Electric connection